

ORIENTATION
 VENT: 12:00 & 6:00
 OUTLET: 9:00
 INLET: 3:00

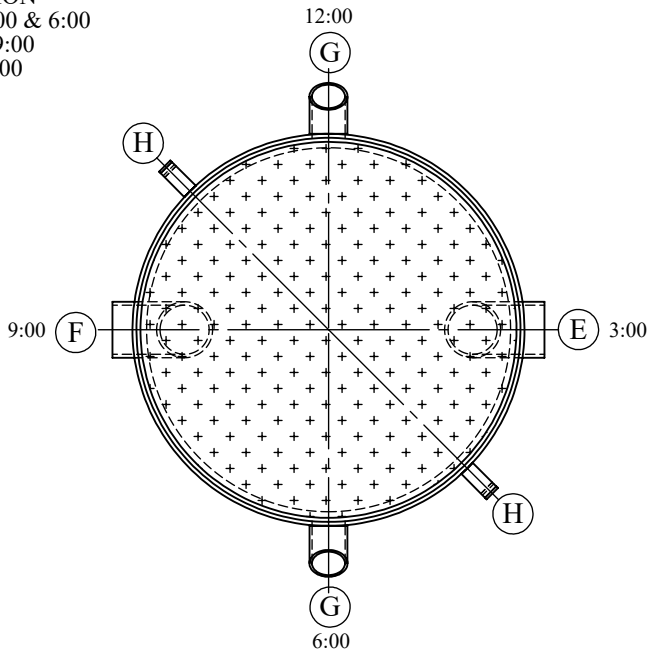

ITEM	QTY.	DESCRIPTION	MATERIAL
A	1	24" I.D. x 48" x 3/16" - SHELL	A36
B	1	24" O.D. x 3/16" - BOTTOM	A36
C	1	24" O.D. x 5/8" SQUARE BAR	A36
D	1	3/8" FLOOR PLATE - COVER	A36
E	1	3"-SCH.40 - 90° INLET	A53E/B
F	1	3"-SCH.40 - 90° OUTLET	A53E/B
G	2	2"-SCH.40 - 45° VENT	A53E/B
H	2	LIFTING LUG	A36

STOCK A7215 3" IN & OUT w/ 2" VENT

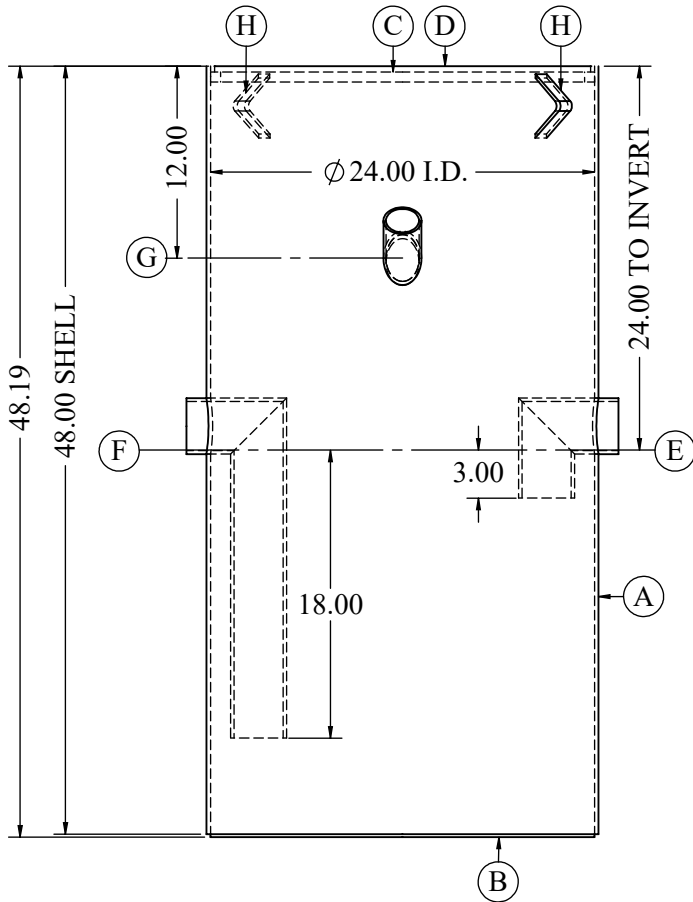

NOTES:

1. 6 CUBIC FT CAPACITY
2. SHOP TESTED WITH 3 PSI (TEST CERTIFICATE SUPPLIED UPON REQUEST).
3. MEETS THE MINIMUM REQUIREMENTS OF 1017.2 NON-RATED INTERCEPTOR.
4. WELDING PERFORMED BY A QUALIFIED WELDER. (A WELDER OPERATOR QUALIFICATION TEST RECORD PER QW484 PROVIDED UPON REQUEST).
5. PROTECTIVE COATING APPLIED INSIDE & OUT.
6. APPROX. WT. 360#.

DRAWING TITLE: 6 CUBIC FOOT INFLAMMABLE WASTE TRAP	CUSTOMER: PROJECT: DWG.No. A7215-3 / PROJECT No.				DRAWING BY: MIKE DATE: 1/29/16
		REV.	DATE	DESCRIPTION	