

WT-125

125 CUBIC FOOT

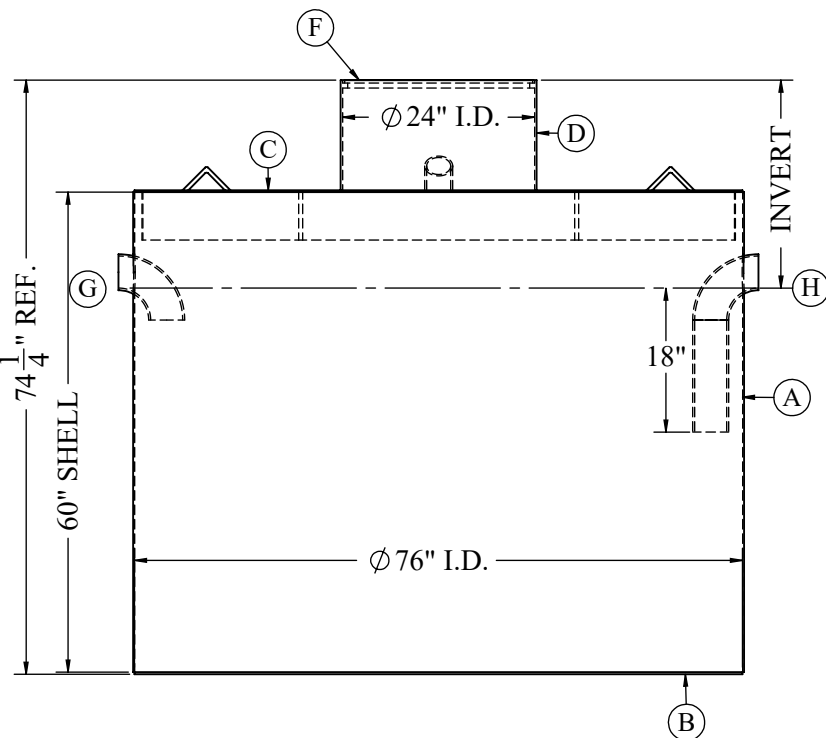
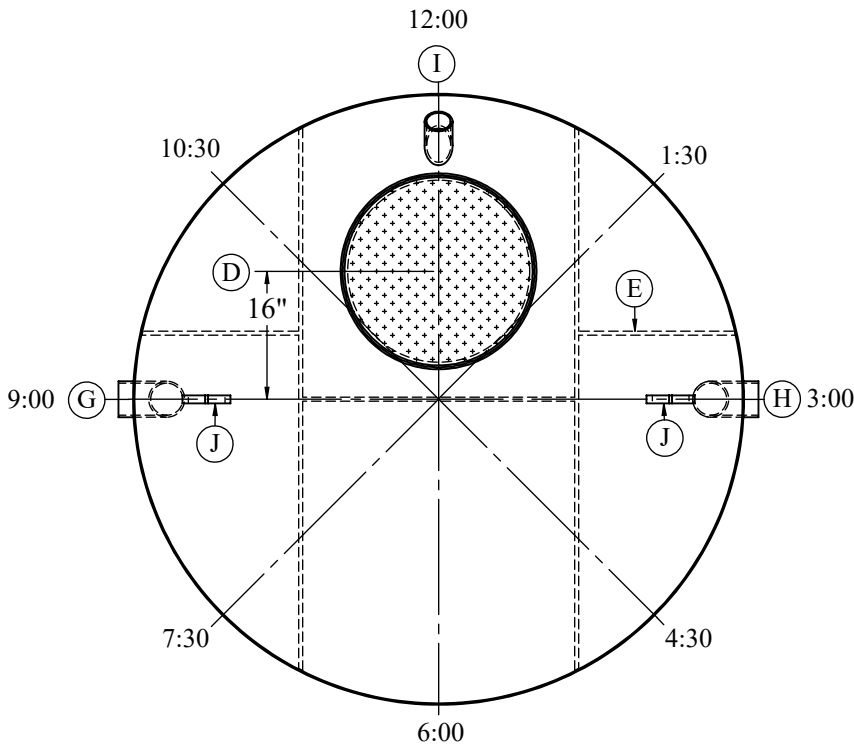

INVERT ELEVATION (STANDARD IS 26")		CUSTOM ELEVATION		
<input type="checkbox"/>		<input type="text"/>		
ORIENTATION	VENT	INLET	OUTLET	
12:00				
1:30				
3:00				
4:30				
6:00				
7:30				
9:00				
10:30				
OPENING SIZES	VENT	INLET	OUTLET	
3"				
4" (STD)				
6"				
8"				
ANTIFLOTATION ANCHOR RING				
COVER OPTIONS	LOOSE	BOLTED	BOLTED & COUNTER-BORED	
STANDARD COVER VEHICLE TRAFFIC				
HEAVY COVER FORKLIFT TRAFFIC				
CAST IRON (NEENAH) FRAME & COVER H2O LOADING				
TANK LINING	INTERIOR	EXTERIOR		
PROTECTIVE COATING (STD)				
COAL TAR EPOXY 8 MILS				
COAL TAR EPOXY 16 MILS				

NOTES:

1. SHOP TESTED WITH 1.5 PSI (TEST CERTIFICATE SUPPLIED UPON REQUEST).
2. THIS OIL AND FLAMMABLE LIQUID INTERCEPTOR MEETS THE MINNESOTA STATE PLUMBING CODE FOR A NON-RATED INTERCEPTOR PER SECTION 1017.1 & 1017.2. LOCAL AUTHORITY HAS JURISDICTION.
3. WELDING PERFORMED BY A QUALIFIED WELDER. (A WELDER OPERATOR QUALIFICATION TEST RECORD PER QW484 PROVIDED UPON REQUEST).
4. APPROX. WT. 1,720#.

DRAWING TITLE: WT-125 INFLAMMABLE WASTE TRAP	CUSTOMER:				DRAWING BY: MIKE
	PROJECT: DWG.No. WT-125 / PROJECT No.				
		REV.	DATE	DESCRIPTION	