

WT-300

300 CUBIC FOOT

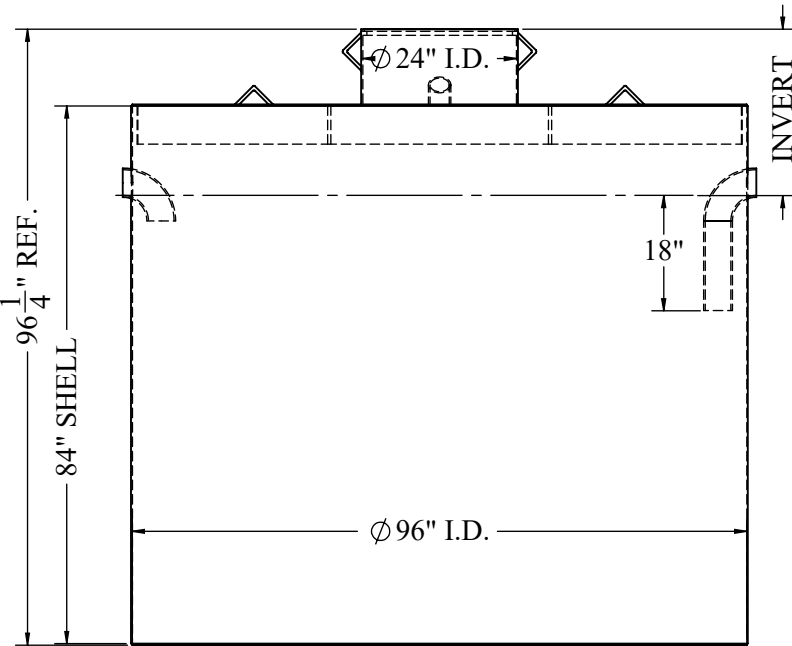
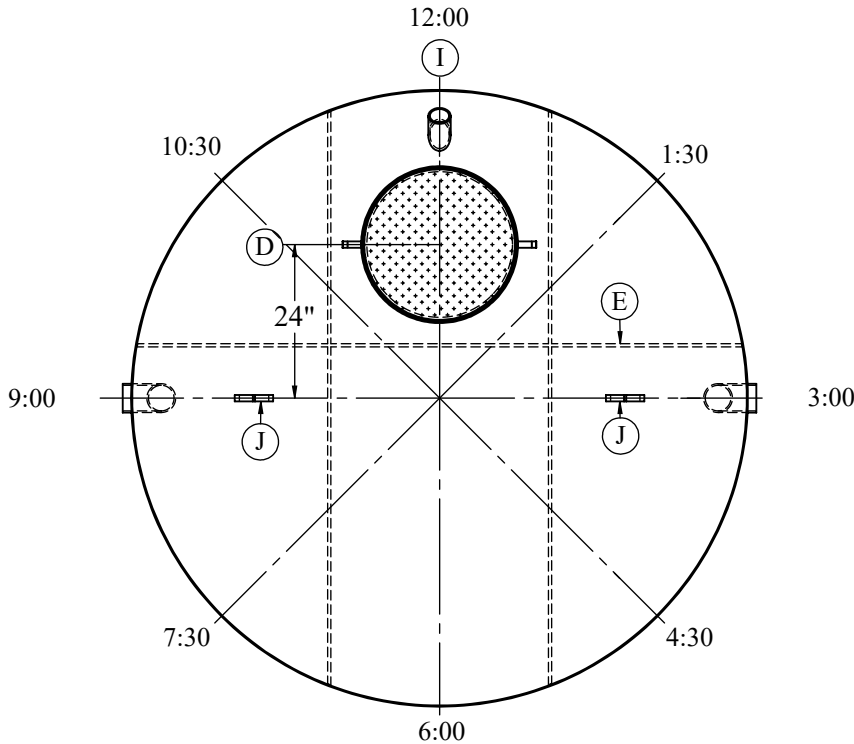

INVERT ELEVATION (STANDARD IS 26") <input type="checkbox"/>		CUSTOM ELEVATION <input type="text"/>	
ORIENTATION	VENT	INLET	OUTLET
12:00			
1:30			
3:00			
4:30			
6:00			
7:30			
9:00			
10:30			
OPENING SIZES	VENT	INLET	OUTLET
3"			
4" (STD)			
6"			
8"			
ANTIFLOTATION ANCHOR RING			
COVER OPTIONS	LOOSE	BOLTED	BOLTED & COUNTER-BORED
STANDARD COVER VEHICLE TRAFFIC			
HEAVY COVER FORKLIFT TRAFFIC			
CAST IRON (NEENAH) FRAME & COVER H2O LOADING			
TANK LINING	INTERIOR	EXTERIOR	
PROTECTIVE COATING (STD)			
COAL TAR EPOXY 8 MILS			
COAL TAR EPOXY 16 MILS			

NOTES:

1. SHOP TESTED WITH 1.5 PSI (TEST CERTIFICATE SUPPLIED UPON REQUEST).
2. THIS OIL AND FLAMMABLE LIQUID INTERCEPTOR MEETS THE MINNESOTA STATE PLUMBING CODE FOR A NON-RATED INTERCEPTOR PER SECTION 1017.1 & 1017.2.
3. LOCAL AUTHORITY HAS JURISDICTION.
4. WELDING PERFORMED BY A QUALIFIED WELDER. (A WELDER OPERATOR QUALIFICATION TEST RECORD PER QW484 PROVIDED UPON REQUEST).
5. APPROX. WT. 2800#.

DRAWING TITLE: WT-300 INFLAMMABLE WASTE TRAP	CUSTOMER: PROJECT: DWG.No. WT-300 / PROJECT No.
---	---